

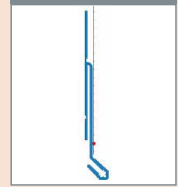

W45-11



APU®

PROFILES FOR COMPOUND HEAT INSULATION SYSTEMS

Flashing bead **FIN-TEX**

With 12.5 cm mesh

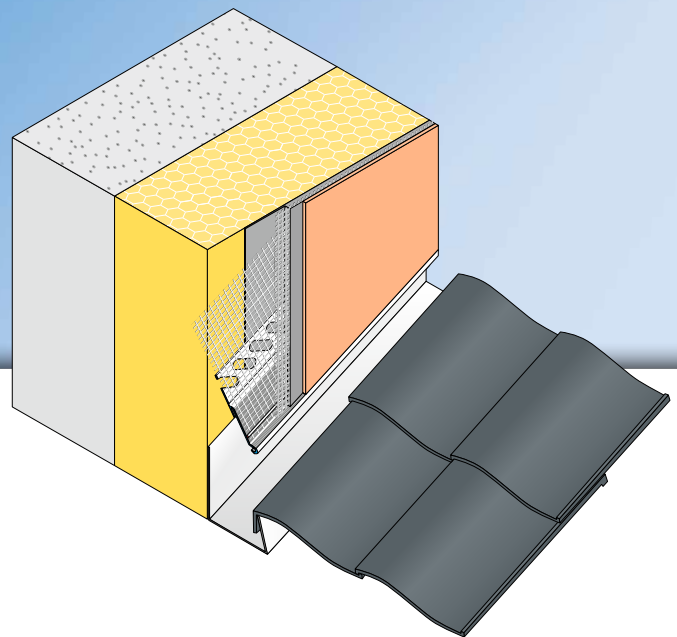

The **APU flashing bead FIN-TEX** is used at junction points with metal plate in compound heat insulation systems (e.g., at junctions with the roof's edge) and as a result of its cavity design produces a flexible connection between plaster and metal. The profile is used for 11 mm plaster thickness and upon completion of the plastering work ensures that water is accurately guided away.

The profile has a welded fabric strip. Each bar has a fabric overhang on one side of 10cm in the lengthways direction. The included plug connectors (Z13) enable the profiles to be joined and fitted very precisely and flush.

What is created after completion of the plastering work is a clean termination of the plaster.



W45-11

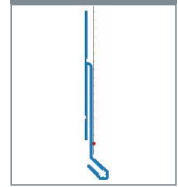

Fitting

- 1 Stick profiles for movement absorption onto the sheet metal, providing a clearance of 10mm. The profile can then thus be fixed in the insulating material using the plug connectors provided.
- 2 Join the profile with the enclosed plug connectors (Z13).
- 3 Fold away mesh and apply reinforcement base plaster. Work mesh in.
- 4 Apply reinforcement base plaster over the full area. In the process, either press the fixing pins completely into the plaster or pull them back out.
- 5 Pull the mesh up to the plaster edge and trim.
- 6 After leaving to stand for the required time, apply covering layer of plaster.

Important information

- Any applications not clearly described in the documents may be implemented only after consultation with the plaster or ETICS manufacturer.
- When the work is being done, the surface temperature must be at least +5 degrees and must not exceed +40 degrees.
- After being set in place on the structural element, profiles with a mesh vane must be promptly embedded. Until then they must be protected from the weather.
- The surface mesh to be subsequently attached must be run up to the skimming edge of the profile.
- Where the profiles are used above 3m length, a flashing strip must be used above the sheet metal.
- The processing guidelines of the plaster manufacturer shall be complied with.